



सत्यमेव जयते

भारत सरकार

Government of India

विद्युत मंत्रालय

Ministry of Power

उत्तर क्षेत्रीय विद्युत समिति

Northern Regional Power Committee

सं.सूक्षेत्रीय/प्रचालन/108/04/2022/11822-11856

No. NRPC/OPR/108/04/2022/11822-11856

दिनांक 07.12.2022

Date: 07.12.2022

सेवा में / To,

संलग्न सूची के अनुसार/As per list attached

विषय: दूरसंचार, स्काडा और टेलीमेट्री उप समिति की 21वीं बैठक की कार्यसूची।

**Subject: Agenda for 21<sup>st</sup> meeting of Telecommunication, SCADA & Telemetry Sub Committee**

महोदय,  
Sir,

इस कार्यालय के पत्र दिनांक 10.11.2022 के क्रम करते हुए यह सूचित किया जाता है कि उत्तर क्षेत्रीय विद्युत समिति की दूरसंचार, स्काडा और टेलीमेट्री (टेस्ट) उप-समिति की 21 वीं बैठक दिनांक **13.12.2022** को **11:00** बजे से वेब-एक्स विडियो कॉन्फ्रेंसिंग के माध्यम से आयोजित की जाएगी। बैठक में सम्मिलित होने के लिए लिंक व आवश्यक जानकारी सदस्यों को ई-मेल द्वारा प्रदान करा दी जाएगी। बैठक की कार्यसूची आपकी सूचना एवं आवश्यक कार्यवाही हेतु संलग्न है। कृपया बैठक में भाग लेने की कृपा करें।

In continuation to NRPC letter of even no. dated 10.11.2022, it is intimated that the 21<sup>st</sup> meeting of Telecommunication, SCADA & Telemetry (TeST) Sub-committee of NRPC will be **held on 13.12.2022 at 11:00 AM via WebEx video conferencing**. The link and necessary information to attend the meeting would be provided to the members via e-mail. The agenda for the meeting is enclosed herewith for your information and necessary action. Kindly make it convenient to attend the meeting.

भवदीय  
Yours faithfully,

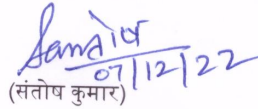
  
(संतोष कुमार)

(Santosh Kumar)

अधीक्षण अभियंता  
Superintending Engineer

## Contents

I.	Confirmation of Minute .....	2
1.	Confirmation of Minutes .....	2
II.	Telecommunication and Telemetry issues .....	3
2.	Issue regarding Non-Availability of Shutdown on 220kV ADHEPL – Phozal & 220kV Phozal - Nalagarh line for aviation Globule removal to carry out the OPGW stringing work on 220KV ADHEPL-Nalagarh link under Reliable Communication Scheme (Agenda by Powergrid) .....	3
3.	Issues in OPGW laying in HPSEBL (Agenda by Powergrid) .....	4
4.	Redundant Communication for Sub-station/Power plant/ Generators (Agenda by Powergrid) .....	4
5.	Telemetry data reporting on single route .....	4
6.	Signing of AMC contract for Synergy make RTUs (replaced by POWERGRID) .....	5
7.	Extension of AMC for Hot Line Speech Communication System (M/s ORANGE) (Agenda by Powergrid) .....	5
8.	Connectivity of Central Control room of Sterlite with Hotline Exchanges (Agenda by NRLDC) .....	5
9.	Non-availability of Real-Time data from PTCUL (Agenda by NRLDC) .....	6
10.	Non-availability of Reliable / Redundant Communication System for PTCUL, SLDC (Agenda by NRLDC) .....	7
11.	J&K Telemetry Issues (Agenda by NRLDC) .....	7
12.	Communication plan for channel redundancy to NRLDC (Agenda by NRLDC) .....	8
13.	Telemetry Issues from POWERGRID Stations (Agenda by NRLDC) .....	9
14.	Telemetry issue from NTPC Singrauli (Agenda by NRLDC) .....	9
15.	Incorrect Solar Generation from Punjab (Agenda by NRLDC) .....	10
16.	Non-modelling of Solar Plants in REMC by RRVPNL (Agenda by NRLDC) .....	10
III.	Issues related to Unified Load Dispatch & Communication scheme of NR .....	12
17.	Issues being faced by HARYANA SLDC .....	12
18.	BBMB Agenda pertaining to ULDC Phase-II and Phase-III SCADA/ EMS .....	16
19.	Issues being faced by UP SLDC .....	19
20.	Issues being faced by Punjab SLDC .....	19
21.	Upgradation of DC Power Supply supplied under ULDC (Agenda by NRLDC) .....	20
IV.	OTHER AGENDA .....	20
22.	Implementation of Automatic Meter Reading (AMR) in Northern Region (Agenda by CTU) .....	20
23.	U-NMS remote console at NRLDC (Agenda by NRLDC) .....	21
24.	Permission to work for Installation of DCPS & Battery and Maintenance activity of existing communication equipment at Manimajra UT sub-station under ULDC scheme (Chandigarh -Panchkula link) (Agenda by POWERGRID) .....	22
25.	Implementation of U-NMS Project (Database development and input for integration) (Agenda by POWERGRID) .....	22
26.	Delay in Payment (Agenda by POWERGRID) .....	23
27.	Settlement of issue of MW tower (Asset of HVPNL) installed at 400KV S/S, Bawana (Agenda by HVPNL) .....	24

## I. Confirmation of Minute

### 1. Confirmation of Minutes

- 1.1. The minutes of 20<sup>th</sup> meeting of TeST sub-committee held on 09.09.2022 were issued on 09.11.2022. Minutes are available at NRPC website (<http://164.100.60.165>).
- 1.2. HVPNL has submitted following comments on the MoM:

Agenda Point	Recorded discussion in the MoM	Amendment requested
17.4 Issue regarding functionality of IMM: Transfer failed	M/s Siemens informed that workaround solution is already provided to HVPNL team and the same has been working satisfactorily. HVPNL stated that they are monitoring the solution and will revert back on any issue	M/s Siemens informed that due to older version of IMM, issue couldn't be resolved permanently. However, to prevent this error frequently, a workaround solution and a write up will be provided to HVPNL.
17.6. Image Backup of servers	Siemens informed that site team is saving the backups in HDD/NAS. There are multiple issues reported with tape drives; hence External HDD is being used	M/s Siemens in the meeting informed that they will start taking image backup and also planning to install Acronis for online Backup of some of the servers.
17.7. IMM in PDS console not working	M/s Siemens informed that although there were some issues with IMM such as sluggish performance, alas it's working. IMM have been improved a lot and its working at HVPNL and other SLDCs.	M/s Siemens stated that they would install another IMM in the operator console instead of the IMM in the PDS machine.

- 1.3. Members may deliberate.

## II. Telecommunication and Telemetry issues

2. **Issue regarding Non-Availability of Shutdown on 220kV ADHEPL – Phozal & 220kV Phozal - Nalagarh line for aviation Globule removal to carry out the OPGW stringing work on 220KV ADHEPL-Nalagarh link under Reliable Communication Scheme (Agenda by Powergrid)**
  - 2.1. The 'Reliable communication Scheme' envisages establishment of 7248Kms of OPGW Network for reliable fiber optic connectivity for Central sector station including IPPs wherein transmission lines 220 kV D/C ADHEPL-Nalagarh is part of the scheme. The OPGW links are being implemented under Package-B: Communication System for Central sector under Northern region-II (Reliable Scheme) awarded to M/s APAR Industries Ltd, Vadodara. Till date, 23 out of 28 links have been commissioned under the said package
  - 2.2. It is to mention that shutdown/PTW is not being issued on 220kV ADHEPL – Phozal & 220kV Phozal - Nalagarh for the carrying out the work on 220KV ADHEPL-Nalagarh link. It is to mention that since December'2021, installation of only 25.865 km OPGW against 177 km (removal of 31 out of 138 no Aviation Globule) has been carried out due to irregular shutdown & PTW issuance from HPPTCL.
  - 2.3. As the remaining aviation globules (107) are to be removed first before stringing of OPGW, ten (10) days shutdown is required for the carrying out the work. Further, 10-12 days shut down shall be required for reinstallation of aviation globules.
  - 2.4. Also, Contractor had deployed the team on site in Feb-Mar'2022 on getting approval for shutdown/PTW in OCC forum, however, their team worked for only 04 days from 17.02.2022 to 20.02.2022 as the consent to issue PTW/shutdown was denied for rest of the approved period. As a result, the team deployed by Contractor had been idle for several days causing financial implications to the agency as conveyed vide their letter dt 11.04.2022 due to irregular issue of shutdown/PTW. Further vide letter ref. no. ADHPL/PGCIL/2022-23/207-209 dt 22.04.2022, M/s AD-Hydro has conveyed that the shutdown is to be further consented by HPSLDC/HPPTCL as the line is connected to Phozal substation of HPPTCL. The letter is enclosed herewith.
  - 2.5. POWERGRID has repeatedly followed up for the issuance of PTW/shutdown with M/s HPPTCL and HPSLDC. However, the consent regarding shutdown/outage has not been granted despite having approval in OCC. HPSLDC, vide email date 29.11.2022 (**Annexure-I**) denied the consent for Shutdown.
  - 2.6. NRPC is requested to intervene for providing shutdown/PTW for OPGW installation works in the above-mentioned link.

### **3. Issues in OPGW laying in HPSEBL (Agenda by Powergrid)**

- 3.1. As discussed in 15th,16th, 17th, 18th ,19th & 20th TeST Sub- committee of NRPC meeting wherein it was deliberated that live line OPGW installation is not possible in 66kV lines, consist of rail pole structure (8 links apprx155km). It is mentioned that strengthening and reconductoring work in 66 kV Gumma-Jutogh line has not been completed till now. It is to inform that OPGW installation work has been completed in 6 out of 8 links.
- 3.2. OPGW stringing work stopped on 66kV Kumaran -Nogli line due non-availability of shutdown since 25 Oct '22 and gang was idle for many days causing financial implications. Contractor has demobilized the gang.
- 3.3. OPGW stringing work could not be started/completed in 66kV Gumma -Jutog link due non-availability shutdown.
- 3.4. HPSEBL vide letter No. HPSEBL/PR&ALDC/CSCAD-15/Vol-II/2022-2398-2405 dated 05 .11.2022 (**Annexure-II**) has informed that they shall not be able to provide shutdown on daily basis on Transmission line till May 2023 due to lean hydro generation and therefore load availability. Copy of letter is attached.

### **4. Redundant Communication for Sub-station/Power plant/ Generators (Agenda by Powergrid)**

- 4.1. Follow up Agenda against 20th TeST Meeting agenda point 2.
  - i. Budhil (Greenco) & Chamera-III (NHPC)
  - ii. Pithoragarh PG, Sitarganj PG, Jauljibi and Dhauliganga
  - iii. Faridabad (FGPP) and Jhajjar NTPC
  - iv. Fatehgarh PS (Adani), Mohindergarh (Adani)
  - v. Narora (NAPP) NPCIL
  - vi. Sambha (PG)
  - vii. Bhinmal (PG)& Kankroli (PG)

### **5. Telemetry data reporting on single route**

- 5.1. Data for following sub-stations/ power plants are also reporting on single OPGW link and the same was discussed in CTU ISTS meeting with all stakeholders.
- 5.2. Further, Shree Cement OPGW connectivity issue was discussed in 57th NRPC meeting under agenda point A.2 wherein, it was deliberated that Shree Cement connectivity shall be discussed separately in upcoming TeST meeting.
  - i. Shree Cement ( No OPGW available, date reporting on PLCC)
  - ii. Saharanpur PG (connected on liner OPGW route)
  - iii. Drass/ Kargil/ Leh/ Klasti (connected on linear OPGW route)
  - iv. RAPP-A & RAPP-B (connected on linear OPGW route)

v. Parbati- 2&3 (No OPGW available, data reporting on BSNL lease line)

## **6. Signing of AMC contract for Synergy make RTUs (replaced by POWERGRID)**

- 6.1. In line with MOU signed by Northern Region Constituents (BBMB, DTL, PSTCL, NHPC, NTPC, NPCIL, SJVNL, THDC and IPGCL) with POWERGRID for replacement of Areva make S900 RTUs (63 Nos. in total). As per MOU, supply and services works was to be executed by POWERGRID and AMC contract shall be signed by respective constituents with successful bidder and maintenance payment shall be made directly by respective owner on quarterly basis.
- 6.2. Now defect liability period for these 63 nos. of RTU has been completed. POWERGRID has issued AMC contract for next 6 years effective from 01.12.2022 to 30.11.2028, M/s synergy has also accepted the same (copy shared with all constituents). In this regards, following need to expedited for smooth running of AMC for RTUs commissioned by M/s Synergy under replacement of S900 package through POWERGRID.
  - i. Signing of Contract Agreement with M/s Synergy Solutions
  - ii. Confirmation for submission of contract performance guarantee for AMC.
- 6.3. All concerned constituents are requested kindly to expedite the signing of Contract Agreement and BG submission may be confirmed as per the contract, so that maintenance activity may carried out by vendor in smooth manner, resulting maximum data availability shall also be ensured.

## **7. Extension of AMC for Hot Line Speech Communication System (M/s ORANGE) (Agenda by Powergrid)**

- 7.1. As all are aware that for hot line speech communication system was implemented by POWERGRID for PAN India basis wherein NLDC, RLDCs and all SLDCs are inter connected through Alcatel Lucent make EPABX system, VOIP/Analog phones are also installed at power plants/sub-station/IPPs, etc over dedicated OPGW network of ULDC. This scheme was executed by M/s ORANGE and 7 years of AMC was also part of the original contract and this AMC going is to expire in coming July' 2023. There is no extension clause in the contract, therefore extension modalities may be discussed in details, being an electronic item, old model, spare unavailability, etc, Replacement/ upgradation of EPABX system may also be discussed among all stake holders.
- 7.2. Agenda is put up for deliberations and future course of action.

## **8. Connectivity of Central Control room of Sterlite with Hotline Exchanges (Agenda by NRLDC)**

- 8.1. Sterlite Power vide letter no: SPTL/O&M/2022-23/11/01 dated 25.11.2022 has informed that M/s Sterlite Power Transmission Limited is setting up Remote

Control Centre at Gurugram intended as central coordination node of all assets/SPV's (including operational and under construction projects) of Sterlite Power.

- 8.2. So, for centralized coordination of the of SPTL central control room at Gurugram with NRLDC, STPL has requested NRLDC allow VOIP link connectivity access of their Control Room with NRLDC and onward towards all other RLDC's.
- 8.3. It may be noted that as per Communication Regulations, 2017 "The CTU shall provide access to its wideband network for grid management and asset management by all users."
- 8.4. In this regard CTU is requested to update procedure to integrated with Hotline exchange.
- 8.5. CTU to update.

## **9. Non-availability of Real-Time data from PTCUL (Agenda by NRLDC)**

- 9.1. As per details submitted by PTCUL out of 58 Sub-Station/Generating Stations data from only 26 Sub-stations are integrated at SLDC. Also, many feeders are not integrated even at the locations where RTUs are installed.
- 9.2. The same issue was also informed to PTCUL vide letter (Ref: - NRLDC/SL-II/2019-20) dated: - 05.03.20.
- 9.3. Issue was discussed in Special Meeting with PTCUL held in July 2020 and December 2020. Subsequently issue was discussed in 17th, 18th & 19th Test Meeting and 45th TCC-48th NRPC and 47th TCC-49th NRPC.
- 9.4. During 47th TCC -49th NRPC dated 27.12.2021, representative from PTCUL informed that they are in the process of tendering of RTU and OPGW Installation work and informed that they would expedite the installation works, and is expected to be completed in 6 months. Further, representative from PTCUL informed that faulty CMRs/Transducers replacement work is in progress and same would be completed within 3 months.
- 9.5. Matter was discussed in various NRPC and TeST Meetings.
- 9.6. During 20th TesT Meeting PTCUL informed that contract for MFT replacement has been awarded and all the faulty MFTs/transducers will be replaced within 2 months.
- 9.7. Further, based on the discussion of 20th TeST Meeting, a DO Letter was issued by MS NRPC to MD, PTCUL.
- 9.8. PTCUL may update the status.

## **10. Non-availability of Reliable / Redundant Communication System for PTCUL, SLDC (Agenda by NRLDC)**

- 10.1. SLDC Uttarakhand is connected to NRLDC through radial network from Roorkee-Dehradun and all services like ICCP, PMU/PDC and VOIP are working on this. Any issue in link leads to outage of Voice and Data communication between SLDC Uttarakhand and NRLDC.
- 10.2. Matter of reliable communication to NRLDC was also discussed in Special Meeting with PTCUL on 07th July 2020 conducted by NRPC, 45th TCC/48th NRPC Meeting dated 02.12.2020 where PTCUL/POWERGRID assured that reliable communication link would be available in 6 months.
- 10.3. Issue was also discussed in 47th TCC/49th NRPC Meeting dated 27.12.2021 , where PTCUL representative informed that they are in the process of tendering of RTU and OPGW Installation work and it is expected to be completed in 6 months.
- 10.4. During 52nd NRPC dated 31.03.2022, PTCUL informed that they are on the verge of finalizing the OPGW project and order will be placed in one-month duration. He proposed that lease line may be used to connect NRLDC. Since Kashipur SLDC is already connected with Dehradun SLDC. Therefore, lease line from Dehradun to Kashipur SLDC may be used.
- 10.5. During 20th TeST Meeting dated 09.09.2022, PTCUL informed that they are in process of integrating redundant link and it shall be commissioned within one month.
- 10.6. PTCUL/POWERGRID may update.

## **11. J&K Telemetry Issues (Agenda by NRLDC)**

- 11.1. Reliability and accuracy of SCADA data and its associated communication system is essential for monitoring and coordinating operations of a large electricity grid. It helps in visualization and management of the critical grid element failure/grid incident in real time and minimizes the possibility of any untoward incidences/disturbances. Network applications in Energy management system (EMS) such as State Estimator (SE), Real Time Contingency Analysis (RTCA) also necessitate reliable and accurate real time analog and digital data. Data communication has to be made through redundant and alternate path communication channel.
- 11.2. Real-Time data availability from Jammu and Kashmir is very poor. There is no visibility of data in J&K stations. With poor monitoring of data, it is very difficult to monitor grid in efficient manner.
- 11.3. The matter has been discussed in various TCC and TeST Meetings but there is no improvement.



- 11.4. Under SCADA upgrade project 66 RTUs were installed by M/s Siemens at all 400KV / 220 KV and 132 KV sub-stations/generating Stations of J&K PDD.
- 11.5. RTUs were not integrated with Control center due to non-availability of communication network.
- 11.6. RTUs were tested locally and commissioned without data availability at Control Centre.
- 11.7. Due to Non availability of data, JK PDD is not able to monitor its drawal from grid and its generation. It is dependent of Central sector data for monitoring of drawal.
- 11.8. Matter was also discussed in Special Meeting with J&K on 28.07.2020 where in Representative of J&K informed that they have given consultancy work to POWERGRID for installation of OPGW in J&K. However, due to funding issue OPGW work has been stalled by POWERGRID. According to J&K almost 95% of the work is complete and once funding issue is resolved Non-availability of telemetry issue will be resolved.
- 11.9. Matter was also discussed in 47th TCC-49th NRPC Meeting dated 27.12.2021, J&K confirmed that they will resolve the issues mutually with POWERGRID so that data starts reporting to SLDC/ NRLDC.
- 11.10. During 19th TeST Meeting dated 07.03.2022 J & K representative informed that by 31st December 2022 all 70 RTUs will be integrated with SLDC.
- 11.11. During 20th TeST Meeting dated 09.09.2022, it was discussed that J&K informed that they are in process of rectification of RTU issues and joint visit is planned with M/s Siemens.
- 11.12. J&K to update the status.

## **12. Communication plan for channel redundancy to NRLDC (Agenda by NRLDC)**

- 12.1. The provision of redundant & reliable communication was discussed in various TeST Meetings. Redundant communication is to ensure that two ports at RTU end are configured for RLDC. Also, data is configured with two different communication channel for bringing redundancy into the system and increase reliability of data to NRLDC/RLDC.
- 12.2. The reliability of communication channel to NRLDC was discussed in various TeST Meeting since November 2016(8th TeST Meeting). It is informing that still 7 RTUs are reporting to NRLDC on single channel.
- 12.3. It is requested to expedite the process of providing redundant channel for the remaining locations at the earliest. It is to note that stations where second is down since long is considered as single channel only.
- 12.4. Thus it is requested that reliability of redundant channel may also be ensured.
- 12.5. List of RTUs with single channel is given below:

S.NO.	Name of RTU	Comments	Timeline
1	KISHANGANGA	NHPC	
2	PARBATI-2	NHPC	
3	BUDHIL	IPP	
4	KARCHAM WANGTOO	IPP	
5	PARBATI-3	NHPC	
6	AD Hydro	AD Hydro	
7	Bhiwadi HVDC	POWERGRID	Second gateway Faulty

- 12.6. Issue regarding Parbati-2, Parbati-3 and Kishanganga was discussed in detail in 20th TeST Meeting, still there is no improvement in this regarding. Data from existing links from these stations is highly unreliable. NHPC /POWERGRID to take urgent action in this regards.
- 12.7. POWERGRID/Utilities are requested to please update the status.

### 13. Telemetry Issues from POWERGRID Stations (Agenda by NRLDC)

- 13.1. SCADA data is very important. Decisions in real-time are taken by Real-time engineers of NRLDC based on real-time data available to Control room. There is requirement of good quality input data for smooth grid monitoring & Control. Further, good telemetry is also essential of running of State Estimator/Energy Management System (EMS).
- 13.2. Since proper telemetry is not available from many POWERGRID substations, it has impact on successful running of state estimator. Correct telemetry is essential for running State Estimator/ Contingency Analysis in EMS, Better SE output will aid in situational awareness of the system operators of NRLDC.
- 13.3. In this regard, letter regarding Telecommunication, SCADA & Telemetry issues from POWERGRID Sub-stations was given by NRLDC vide NRLDC/Telemetry/ dated 15 Dec 2021. Although there is improvement with respect to issues raised but data from many sub-stations is still unreliable.
- 13.4. It is requested to please take up for rectification of data on priority basis and confirm the dates of resolution of the points.
- 13.5. During 19th / 20th TeST Meeting POWERGRID informed that issues of Balia and Bhiwadi HVDC is in process of award for integration works at Balia and Bhiwadi HVDC and informed the work will be completed within 1-2 months.
- 13.6. POWERGRID to update the status.

### 14. Telemetry issue from NTPC Singrauli (Agenda by NRLDC)

- 14.1. Presently SCADA data from NTPC Singrauli is updating at NRLDC through two RTUs, one is old S900 RTU and other one is new Gateway which is under

commissioning at NTPC Singrauli. Some of the bays where SAS upgradation work has completed, data from those bays are reporting through new Gateway and remaining bays are still reporting through old RTU.

- 14.2. However, Old RTU was commissioned under ULDC Phase-1 and AMC for the RTU is also not available. Any issue in the bays where not yet upgraded remains unattended. Presently data of Rihand-2 and Vindhyanchal-1 is not updating correctly at NRLDC. Matter has been taken up with NTPC many times but the issue is yet to be rectified.
- 14.3. NTPC is requested to take immediate action for resolution of the same.
- 14.4. NTPC to update the status.

### 15. Incorrect Solar Generation from Punjab (Agenda by NRLDC)

- 15.1. Solar Generation from Punjab is showing non-zero values at night hours and sometimes sudden excursions occurs in Solar Generation leading to incorrect reporting and forecasting .
- 15.2. Sample trend of Punjab Solar is given below:

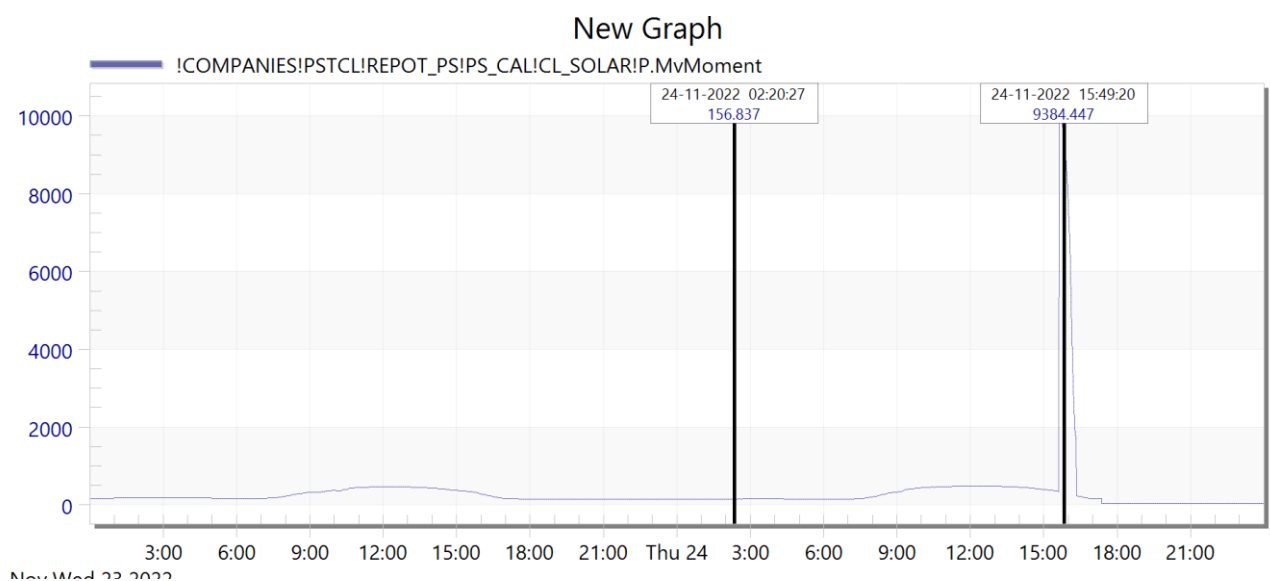

- 15.3. PSTCL is requested to please take urgent action for resolution of the telemetry issue from Solar Plants.

### 16. Non-modelling of Solar Plants in REMC by RRVPNL (Agenda by NRLDC)

- 16.1. Forecasting and scheduling software were supplied at RRVPNL in 2020 under Renewable Energy Management Centre (REMC). The main function is to forecast Solar and Wind plants of Rajasthan state and their scheduling.

- 16.2. However it is to inform that all Solar plants are not modelled in Rajasthan REMC forecasting tool . Against installed capacity of 4210 MW only 3605 MW is modelled in REMC forecasting tool which leads to wrong interpretation/forecasting in REMC tool at NRLDC / NLDC and discrepancy between REMC report and other Power Supply position reports.
- 16.3. RRVPNL is requested to please take up and resolve the issue of modelling of plants in REMC at the earliest.
- 16.4. Further, scheduling tool supplied under REMC is not being used by Rajasthan, Rajasthan may please appraise the issue regarding non-usage of REMC scheduling tool.
- 16.5. Rajasthan may please update.

### III. Issues related to Unified Load Dispatch & Communication scheme of NR

#### 17. Issues being faced by HARYANA SLDC

##### 17.1. Non-displaying of Dynamic Values on SLDC Haryana Website:

Initially this issue remained pending for about 1.5 years and resolved in April, 2022. But in May 2022, the issue has been re-appeared. In the 20th TeST meeting, Siemens informed that “after lots of efforts they couldn't restore the values. The next viable option is to rebuild the COL database which is a time-consuming activity and it would take approx. 3 days of downtime of website. Siemens stated that it will explore other options for this activity.” However, the ground reality is completely different from this. Ever since the issue resurfaced, M/s Siemens has neither taken any action on it nor has they shared any update till date. Whereas they were repeatedly reminded of the matter through meeting and various correspondences.

So, M/s Siemens may be asked to update the progress and resolve this issue at the earliest.

##### 17.2. E-DNA new data points list not updating in e-DNA ChAD manager & Loss of data: -

For the last 8 months up-dation of newly created points in ChAD manager of e-DNA software have been stopped resulting in interruption of access of historical data through their ChAD ID. In the 20th TeST meeting, M/s Siemens informed that “Issue is pending with the OEM of eDNA and their partner Kalkitech. They have tried multiple time to resolve the issue. We are awaiting to get a resolution.” Apart of this, recently an issue was occurred in e-DNA application and historical data have been lost for almost 3 hours.

As informed by M/s Siemens, M/s Kalkitech has been taken over by another company and it is also informed that the new company is not providing any solution to resolve these issues.

In view of the above, M/s Siemens may be asked to submit its response to the following: -

- a. How much more time will it take to resolve the above issue?
- b. Action taken since the last test meeting to address these issues?
- c. How will the existing issues/future issues with e-DNA be dealt with?

**17.3. Dependency of Site Engineer on one or two engineer deputed at NRLDC and Regarding Contractual obligation (qualification) of Site engineer: -**

Issue was highlighted no. of times by HVPNL as well other SLDCs. In the 20<sup>th</sup> TeST meeting, Siemens informed that *“although training is imparted to their newly recruited site engineers, their site engineers are of L1 expertise level and require support from senior engineers (L2/L3 level) in some cases.”*

However, in reality, due to lack of basic knowledge of the system, engineers have to seek support on every issue and sometimes, due to senior team's occupancy at their own site/other sites, it takes more time than expected to resolve the issue. It is pertinent to mention that both the recently recruited engineers haven't been given any kind of system related training before their deputation. Although one engineer who was deputed for training at other site for 3-4 days is on medical leave for last 1 month and no replacement / stop gap arrangement has been provided.

So, M/s Siemens may be asked to oblige conditions of contract and deployment of qualified and well-trained engineer only.

**17.4. Issue regarding functionality of IMM: - Transfer failed:**

M/s Siemens in the last TeST meeting as well many other occasions have stated that they will provide a workaround solution and provide a write up to prevent this transfer failed error. Although same hasn't been provided yet.

**17.5. Compatibility of Siemens web-server:**

Webserver is not compatible with TLS V1.2 or higher. Due to this, the website is not available on different updated browsers. M/s Siemens has stated in the 20<sup>th</sup> test meeting that Web-server requires additional development, they are expecting to finish the new development soon.

M/s Siemens may be asked to update the progress and resolve this issue at the earliest.

**17.6. Image Backup of servers:**

M/s Siemens was asked several times to certify that the image backups of all the servers have been taken. But they haven't given certificate on it yet. It is pertinent to mention here that backup of servers is more important for Siemens rather than states.

As per the MoM of the last meeting, M/s Siemens has stated that “site team is saving the backups in HDD/NAS.” Although amendment has been requested in the MoM as Siemens in the meeting informed that they will start taking fresh image backup and also planning to install Acronis for online Backup of some of the servers.

M/s Siemens may be asked to provide the update on the progress and give undertaking that all image backup have been taken in the tape drives / Hard disks.

**17.7. IMM in PDS console not working:**

This issue is pending since 2018. It was working for some time in 2020 (1 month) but then later stopped working again. The matter was discussed several times but each time a new time line was given by M/s Siemens for its resolution. The last deadline was March 31, 2022 given in 19th test meetings.

In the 20th TeST meeting, it was proposed that M/s Siemens would install another IMM in the operator console instead of the IMM in the PDS. However as per MoM of 20th TST meeting, it is mentioned that "there were some issues with IMM like sluggish performance, sorry it is working", which is not true. A separate request for amendment in the MoM in this regard has been made.

M/s Siemens may be asked to apprise that what action has been taken on this so far and how much more time it will take to complete this activity.

**17.8. AMC Payment issue:**

- a. **Non issuing AMC invoices Since Jan-2022:** - M/s Siemens is not generating invoice bill to the constituent states since Jan-2022 whereas all the quarterly availability reports were submitted timely till date. M/s Siemens may be requested to update on these as constituent states have to submit budget requirement to their respective account wing accordingly.
- b. **Clarification on availability report for the quarter Jan-2022 to March-2022:** As per HVPNL calculation, availability of said quarter comes out to be 85.22% (due to non-availability of one site engineer for 2 complete month) and same was submitted to M/s Siemens with complete calculation sheet. **(Annexure-III)**

As per condition of contract, each engineer has their designated role and it is clearly mentioned in the contract and reproduced as below: -

As per AMC contract agreement clause 4.2.1. *"The contractor's on-site support for Main Control Centre shall be standard hours of service i.e., Monday to Saturday- 9:00am to 5:30pm local time (IST), excluding Public and Owner company holidays, throughout a year, **at least one Software Engineer and One Hardware Engineer** having expertise in SCADA/EMS system shall be available during the standard hours of service at each Main Control Centre."*

Further as per clause 4.5.1, details of different severity levels, Severity-2 outages/disruptions defines that "non-availability of **designated contractor's man-Power** at Control Centre as well as required inventory of spares specified here."

M/s Siemens had requested to review the calculation of availability of the said quarter. As per their claim, non-availability hours of the said quarter shall be halved due to availability of at least one engineer at site.

It is also stated by M/s Siemens that PowerGrid agree with the same.

Being a contractual owner of the project, PowerGrid was requested to clarify whether the calculation made by HVPNL for the said quarter is as per contract or not and suitable justification may also be submitted by PowerGrid, in case of different opinion (**Annexure-III**). Although reply from PowerGrid is awaited on this.

Being contractual owner of the project, PowerGrid may be requested to clarify the clause of the contract.

**17.9. Regarding extension of AMC of existing SCADA System installed under ULDC Phase-II.**

The existing SCADA work for Northern Region was awarded in September 2012 through POWERGRID and the System was commissioned in December 2015. The contract has the provision of six-year Annual Maintenance Contract (AMC) after expiry of warranty period. Accordingly, AMC of the same started in April 2017 and it is going to expire on 31.03.2023. The existing system have the provision of extension of AMC for 2 more years on the same terms and condition of the contract.

As the ULDC Phase -III project is also going to be executed in a similar manner by PowerGrid and currently technical specification finalization is under process. Parallel operation of ULDC Phase-III is likely to be commenced from mid-2024. In such a situation the existing SCADA system AMC needs to be extended.

Being a contractual owner of the project, PowerGrid is requested to expedite the process and necessary formal request letter may be submitted to constituent states so that consent may be provided timely after taking necessary approval from management.

**17.10. Replacement/Up-gradation of SCADA-EMS System under ULDC Scheme Phase-III- Modalities of 7 years AMC: -**

In the 58th NRPC meeting held dated 30.09.2022 through VC, PowerGrid informed that the AMC of the upcoming SCADA will be done in a similar manner as being done in the ULDC Phase-2.

In this regard we would like to draw your kind attention towards MOM of 18th TeST meeting (S. No. 5.1) held on 10.08.2021. In the meeting, PowerGrid gave a detailed presentation to carry SCADA Replacement/Upgradation for all utilities



under ULDC Phase-III. In the said meeting, ED/PowerGrid had presented their proposal and one of the highlights of their proposal was as follows: -

" Since states have signed the maintenance contract themselves in ULDC Phase-II and are facing a lot of issues, POWERGRID is willing to cover the O&M part as well during ULDC Phase-III. "

Now PowerGrid is changing its stance. Considering the already approved proposal submitted by PowerGrid and issues being faced in the existing AMC ULDC Phase-II SCADA, PowerGrid is requested to review their decision and stick with their original proposal i.e., covering the O&M (AMC) part as well by PowerGrid.

## **18. BBMB Agenda pertaining to ULDC Phase-II and Phase-III SCADA/ EMS**

### **18.1. Modalities for 7year AMC of the SCADA/EMS system.**

During the 58th NRPC Meeting held on 30.09.2022 held through VC, POWERGRID informed that for ULDC Phase-III, AMC may be taken up directly between the state utility (of respective SLDC) and the AMC vendor with no involvement of POWERGRID. The NRPC Forum decided that the matter may be discussed in special TCC. However, the discussion is yet to take place even though the 59th NRPC Meeting has already been conducted.

This office vide its letter no. 3921-30 LD/G-181 dated 18.10.2022 has requested to review this matter and cover the O&M part during ULDC Phase-III. However, any response in this regard is still awaited.

In this regard, this kindly refer to 18th TeST Sub-Committee meeting of NRPC held on 10th August, 2021 (copy of MOM attached), where POWERGRID gave a detailed presentation for its proposition to carry SCADA replacement/up gradation for all utilities under ULDC Phase-III in a similar manner to ULDC Phase-II. Further in S.No. 5.1 Implementation and funding of Unified Load Despatch and Communication (ULDC) Phase—III. POWERGRID had highlighted the following advantages of their proposal over POSOCO's proposal which included the following:

- Since states have signed the maintenance contract themselves in ULDC Phase-II and are facing a lot of issues, POWERGRID is willing to cover the O&M part as well during ULDC Phase-III.

In last one year, several ULDC Phase-III meetings have been conducted to finalise the technical specifications, where discussion about the amount to be paid to POWERGRID (% charges of AMC) for cover the O&M part has taken place. Then the change in stance at this stage is not understood.

BBMB is under considered view that POWERGRID should adhere by its commitment made in the 18th NRPC meeting and cover the O&M part as well during ULDC Phase-III as it has already acknowledged the fact that states are facing a lot common of issues with the ULDC Phase-II vendor M/s Siemens.

POWERGRID is again requested to review this matter and cover the O&M part during ULDC Phase-III.

#### **18.2. Implementation of Cyber Security measures in SCADA/EMS — Centralized Patch management/Security controls.**

During the 58th NRPC Meeting, POWERGRID proposed that the Centralized Patch management/Security controls for SCADA/EMS System under ULDC Phase-III. The forum also decided that centralized patch management would be a better option. In this regard, it is requested that POWERGRID, POSOCO and all SLDCs may jointly prepare the procedure for centralized patch management. Accordingly, the necessary changes may be made in the BOQ/Technical Specifications of ULDC Phase-III.

#### **18.3. AMC extension of SCADA/EMS System under ULDC Phase-II scheme**

During the 58th NRPC Meeting, POWERGRID informed that Up gradation of SCADA project is likely to be commissioned from January, 2025 to June, 2025 in phased manner. Accordingly, RLDCs/State utilities may extend their ongoing AMC contract for a period of two years as per provisions of AMC contracts. Further, it has been learnt that POSOCO (NRLDC) and POWERGRID are already in touch with M/s Siemens regarding AMC extension. In this regard, it is pertinent to mention that the current license of Fortigate

Make Internal Firewall installed has current validity till 30.04.2023. POWERGRID & POSOCO are requested to ensure that M/s Siemens takes all necessary steps and measures in advance to ensure timely extension of any such licenses and any other necessary support required till the end of AMC period to ensure the system runs smoothly as per the AMC contract (current/extended)

**18.4. Regarding provision/funding for real-time telemetry & 100% visibility of Grid through PSDF.**

With reference to CISO/POSOCO office letter no. CC/Engineering/Sep2022/CERT-GO/NewDPR dated 13.9.2022 received from CISO/POSOCO (copy enclosed) point no.4, where it has been stated that for 'Communication of AMR and real-time telemetry & 100% visibility of Grid' 50% funding can be obtained from Power System Development Fund (PSDF). As per this clause, it is inferred that real-time telemetry & 100% visibility of Grid can be achieved only through successfully commissioned SCADA system. Hence, the replacement/up gradation of SCADA/EMS System under ULDC Phase-III scheme be covered under this project. Thus, it is also requested to consider 50% funding of ULDC Phase-III scheme including cyber security tools and functionalities as mentioned above through PSDF to reduce the financial load on SLDCs and the remaining 50% of the payment maybe charged through Tariff Mode as is being carried out in ULDC Phase-2 scheme.

**18.5. Regarding Capacity Building for central/state utilities (100% funding may be done through PSDF)**

With reference to the CISO/POSOCO letter mentioned in point no.3, it is suggested that the various cyber security tools, cyber security/SCADA/EMS trainings, other cyber security related measures etc. proposed Under ULDC Phase-3 scheme or be brought in future as per the need of fast evolving cyber security posture may be included and 100% funding may be done through PSDF for the same.

**18.6. Regarding implementation of Security Operation Centre (SOC)**

With reference to the letter received from CISO/POSOCO office letter no. CC/Engineering/Sep2022/CERT-GO/NewDPR dated 13.9.2022 (copy enclosed), SOC has to be established for real time cyber security monitoring of SLDCs. The SCADA system installed at SLDC, BBMB has been setup under ULDC Phase-2 scheme of PGCIL, which is common for all Power Sector constituents of Northern Region.

In respect of the above scenario, it is proposed that a common SOC be prepared for all willing SLDCs (of NR) as already done for RLDCs & NLDC. It is requested that views/comments of all SLDCs maybe taken on the following points:-

- i. As SCADA system installed under ULDC Phase-2 scheme has similar setup/infrastructure for all SLDCs, therefore the cyber security risks/threats related to SLDCs are also similar. Therefore, views on joint roadmap for establishment of SOC maybe taken.
- ii. A common philosophy/ establishment of single SOC which can cater to the cyber security requirements of all SLDCs maybe commented upon.
- iii. As SCADA system setup at respective SLDCs has been installed by the same vendor i.e. M/s Siemens under ULDC Phase-2 scheme and the vendor is also going to be a single company for Phase-3 scheme also, thus issues that can arise in respect of the coordination between the firm establishing the SOC for SLDC and the vendor for the ULDC scheme maybe commented upon.

In this scenario a common SOC can be helpful for effective, timely and cost effective methodology for implementation at SLDCs.

## **19. Issues being faced by UP SLDC**

- 19.1. **SCADA Upgradation Project ULDC Phase-III:** As the SCADA Upgradation project under ULDC Phase-III is being implemented by PGCIL and the project has been delayed and likely to be commissioned in 2024/2025. It is requested that PGCIL to jointly negotiate with Siemens on behalf of all Northern Region constituents for extension of AMC contract, as per the requirement.
- 19.2. PGCIL to apprise the Status and timeline of implementation of the ULDC-III project.
- 19.3. PGCIL to hold a joint meeting with all the constituents of NR regarding the revised BOQ items .
- 19.4. PGCIL to share the final DPR and final estimated cost of the project under ULDC -III, so that administrative & financial approval can be sought from Management/BoD.

## **20. Issues being faced by Punjab SLDC**

- 20.1. **Regarding suspected data of Power Grid Intrastate drawl Points:** In this regard, it is informed that PGCIL Amritsar 400 KV ICTs SCADA data remains suspected/ struck most of the time, which causes a problem for control room operators in controlling the Grid. Similarly, Scada data of 400KV Ludhiana substation of Powergrid was also suspected for few days due to problem of the RTU, which is not desirable & needs to be immediately attended. As such, it is requested to ensure the accuracy of data of all the PGCIL interstate stations of Punjab.
- 20.2. **Cyber security of SCADA system:** Detailed cyber security compliance report of VAPT Test held in May'22 by M/s Siemens is still pending. M/s Siemens has been requested multiple time but still it is pending, kind request to take up the matter with Siemens please.

- 20.3. **Extension of ULDC-II SCADA system AMC to M/s Siemens:** It is requested that AMC may be extended for further 2 years i.e. upto March'2025 for the current ULDC Phase-2 Project at centralized level by PGCIL for all the Northern region SLDCs.
- 20.4. **Installation of SOC:** In reference to a letter received from CISO/POSOCO, Security Operation Centre (SOC) has to be established for real time cyber security monitoring of SLDCs. In this respect, it is proposed that a common SOC be installed for all willing SLDCs as already done for RLDCs & NLDC. The views of other SLDCs may be taken on this proposal. Further the SOC may be the part of ULDC-III & offered 100% funding for SOC by POSOCO may be taken by PGCIL on behalf of SLDCs.
- 21. Upgradation of DC Power Supply supplied under ULDC (Agenda by NRLDC)**
- 21.1. Presently 60A DCPS is installed at NRLDC. DCPS was installed under ULDC Phase-I and is working at full load. Being obsolete, spare parts of DCPS are not difficult to arrange. Any issue in DCPS may lead to failure of DC Supply to communication equipment.
- 21.2. POWERGRID/CTU may take necessary action for replacement /upgradation of DC power supply at the earliest.
- 21.3. Issue was discussed in 19th/20th TeST Meeting and POWERGRID informed that DCPS at NRLDC was missed under reliable scheme and confirmed they will procure/replace DCPS at NRLDC under upcoming project.
- 21.4. POWERGRID to update the status.

#### IV. OTHER AGENDA

- 22. Implementation of Automatic Meter Reading (AMR) in Northern Region (Agenda by CTU)**
- 22.1. Government of India (GoI) has set a Renewable Energy (RE) target of 500GW by 2030. The need for implementing 5-minute meters along with AMR system for regional energy accounting and settlement at the Inter State level has been recommended in FOR sub-group report ,2018 considering the variability of load due to large RE penetration in the coming years. Subsequently, need of AMR has also been discussed in RPC forums considering the high-volume & variable meter data and processing of the same in a very efficient manner.
- 22.2. A PAN India pilot project on 5-minute metering was implemented as per the directive from Hon'ble CERC. A report on the pilot project covering implementation aspects, challenges and suggested way forward has been submitted by POSOCO for perusal of the Hon'ble Commission and further directions.

- 22.3. Moreover, in view of the new DSM regulation 2014 and its amendments, which are more stringent, there is a need expressed by States to get streaming online instantaneous MW data at a user configurable rate (minimum 1 min) at SLDCs via AMR system.
- 22.4. In view of the above a meeting was held on 19.11.2020 chaired by Chairperson, CEA with the participation from PGCIL, CTU, POSOCO, RPCs etc. on the subject of Telemetry of real time Active Power (MW) data to SLDCs. After deliberation in the meeting, it was decided to constitute a committee for finalizing the Technical Specification (TS) of the Interface Energy Meters along with Automatic Meter Reading and Meter Data Processing system for ISTS metering points.
- 22.5. NPC Division, CEA vide letter dated 02.12.2020 had constituted a joint committee comprising the members from each RPC, CEA, CTU/PGCIL & POSOCO "to prepare the Technical Specifications (TS) of the 5/15 Minute Interface Energy Meters (IEMs) with Automatic Meter Reading (AMR) and Meter Data Processing (MDP) for interstate transmission system at PAN India basis".
- 22.6. NPC Division, CEA vide letter dated 6th July 2022 had circulated the final copy of "Technical Specification (TS) of Interface Energy Meters, Automatic Meter Reading system and Meter Data Processing system" provisioning all the requirements mentioned above.
- 22.7. In reference to the above and also as per the draft IEGC 2022 for implementation of AMR project for all the five regions; the proposal from CTUIL for implementation of same in Northern Region is attached herewith (**Annexure-IV**) for deliberation.
- 22.8. MDP system which is also part of the above TS mentioned in point (v) above shall be implemented by NRLDC/POSOCO by their own and would match the timeline schedule with AMR project.
- 22.9. Members may deliberate.

### **23. U-NMS remote console at NRLDC (Agenda by NRLDC)**

- 23.1. POWERGRID is commissioning U-NMS in northern Region through M/s Sterlite. However, it is learnt that POWERGRID has not envisaged U-NMS remote console at NRLDC.
- 23.2. It may be noted that U-NMS is necessary for reports generation regarding non-availability of the links. RLDC has to furnish the availability of communication links etc as per clause 7.3 of the (Communication System for inter-State transmission of electricity) Regulations, 2017 quoted below:  
*"The RPC Secretariat shall certify the availability of communication equipment for CTU, ISGS, RLDCs, NLDC, SLDCs based on the data furnished by RLDC"*
- 23.3. It may be noted that availability of links can be verified based on U-NMS reports. It is requested that remote console may be supplied under U-NMS to NRLDC also.

23.4. POWERGRID to update the status.

**24. Permission to work for Installation of DCPS & Battery and Maintenance activity of existing communication equipment at Manimajra UT sub-station under ULDC scheme (Chandigarh -Panchkula link) (Agenda by POWERGRID)**

24.1. The matter was raised in 19th & 20th TeST Committee meeting but agenda point was not deliberated as representative of UT Chandigarh was not present in the meeting and issue remain undiscussed/unresolved.

24.2. NRPC is requested to intervene for providing entry permission from UT Chandigarh for DCPS, OPGW installation under Reliable communication scheme and for regular/day to day maintenance issues.

**25. Implementation of U-NMS Project (Database development and input for integration) (Agenda by POWERGRID)**

25.1. For commissioning of U-NMS Project, database development is required which requires details of existing NMS of centre sector / state sector/ IPPs / Solar developer/ other transmission licensee and independent nodes which are reporting data for grid operation. Technical details/ information pertains to integration has been obtained / being obtained for POWERGRID installed NMS system(s) which were part of ULDC schemes, whereas details from state sector/ IPPs / other transmission licensee are still not been provided to UNMS vendor, which will delay the works for database development and integration.

25.2. POWERGRID along with M/s Sterlite Technology (implementing agency) is regularly pursuing the OEM/state utilities for providing details of NMS system which were implemented by State utilities/other transmission licensees including IPP/ Solar developer. For ex. Sterlite is regularly visiting Rishikesh, Panipat, Lucknow, Shimla for integration of GE, Keymile, Fibcom make NMS system but input details are neither available with state utilities nor OEMs are supporting during visits.

25.3. HVPNL's case, M/s Velocis (KEYMILE make Equipment) is very reluctant in providing details mentioning non-availability/non-support from OEM as this make/model of equipment/NMS is of absolute technology and Keymile (Now ownership is with Hitachi) is also not having proper support for this NMS. They mentioned that in case any issues observed during integration/ running of third party script in this NMS, M/s Velocis may not be able to restore the system and grid operation data reporting at SLDC Panipat will be affected very seriously. Several correspondences were made, separate meetings have been conducted parallelly.

25.4. Other case of PTCUL where, GE make NMS is installed for approx. 18 nos of equipment but only 2-3 equipment are integrated with NMS rest are either not integrated with PTCUL NMS installed at Rishikesh or not reporting anywhere.

- 25.5. Recently POWERGRID has commissioned ABB/Hitachi make NMS for ULDC system at NRLDC where all ABB make equipment can be integrated for Northern Region, so that these equipment can be integrated with U-NMS scheme easily but support from IPP/Solar park owners may be required (calling of ABB engineer at site for integration). In this regard, instructions are required from NRPC forum/CTUIL / NRLDC, so that they may turned up for integration in centralized communication NMS system.
- 25.6. Above issues, may be deliberated in details, so that this critical project of centralized communication system may be implemented and utilized by all stakeholders of Northern Region.

## 26. Delay in Payment (Agenda by POWERGRID)

- 26.1. POWERGRID is providing consultancy services on RTU/APS/Wideband/OPGW maintenance to constituents on overhead charges basis as per MOU signed with respective Constituents. Constituents are paying on quarterly or yearly basis with advance payment. Most of the constituents informed that they have made payment but payment details are not shared by constituents in most of the cases. In some cases data is not provided by constituents since 4-5 years and POWERGRID's management is very serious against these outstanding payments. Auditors has raised serious issues for non-settlement of payment in SAP / POWERGRID books.
- 26.2. Some states are not serious, neither proving details nor replying mails, specially UPPTCL, PTCUL and J&K PDD. POWERGRID have no other option but to cancellation of the AMC with immediate effects. Separate Mails/letters has been sent to respective utilities for providing details, all constituents are once again requested to deposit balance payment and details may also be provided for payment made. TDS details may also be provided.
- 26.3. As on date outstanding amount is Rs 1.59 crores.

Sr. No.	Constituent's Name	Amount
1	JKPDD	Rs. 34.48 Lacs
2	PTCUL	Rs 21.49 Lacs
3	UPPTCL	Rs 17.09 Lacs
4	PSTCL	Rs 53.32 Lacs
5	DTL	Rs 7.76 Lacs
6	HPSEBL	Rs 18.13 Lacs
7	HVPNL (BBMB portion)	Rs 6.99 Lacs
<b>Total</b>		<b>Rs 159.26 Lacs</b>



**27. Settlement of issue of MW tower (Asset of HVPNL) installed at 400KV S/S, Bawana (Agenda by HVPNL)**

- 27.1. In 18th TeST meeting, an agenda was put up for consideration of NRPC, upon which it was suggested by Member Secretary / NRPC to HVPNL & DTL to sort out this bilateral issue mutually. It is added that HVPNL management had already approved the proposal of DTL regarding usages of MW tower and conveyed to DTL during December – 2021. The copy of MOM with DTL is placed at **Annexure-V** & letter regarding approval of HVPNL management is placed at **Annexure-V**.
- 27.2. During 19 TeST meeting held on dated 07.03.2022 through video conference the agenda was again put up and it was requested to DTL to expedite the settlement of the issue of MW tower installed at 400kV substation Bawana. It was assured by representative of DTL that NOC given by HVPNL is under consideration of DTL Management and the issue will be resolved by next month. It has been more than 8 months since then but DTL has not handed over the equivalent iron scrap of weight 66.8MT and the issue is still unresolved. The agenda could not be deliberated during 20th TeST meeting due to non-availability of DTL representatives.
- 27.3. Therefore, DTL may be emphasized to get resolve the long pending issue, the vendor M/s Maa Chintpurni Traders, Patiala is pressing very hard for collection of MW tower material standing at 400KV S/Stn, Bawana.

Furkan Ahmad Siddiqui {फुरकान अहमद सिद्दीकी}

**From:** Power Controller HP-SLDC <pchpsldcshimla@gmail.com>  
**Sent:** Tuesday, November 29, 2022 3:31 PM  
**To:** RTAMCJammu  
**Cc:** Control Room; nrlcdcso; Jagat Ram (जगत राम); Furkan Ahmad Siddiqui {फुरकान अहमद सिद्दीकी}; Rakesh Kumar Gupta (राकेश कुमार गुप्ता); NRLDC Outage; Se Sldc  
**Subject:** Re: Regarding SD of 220KV Ad Hydro Nalagarh (Parni) line and 220KV Nalagarh Phozal line  
**Attachments:** image005.jpg

**Warning:** This email has not originated from POWERGRID. Do not click on attachment or links unless sender is reliable. Malware/ Viruses can be easily transmitted via email.

Sir,

Kindly refer to the trailing mail regarding shut down on 220 KV AD Hydro – Nalagarh line and 220KV Nalagarh – Phojal line from 01.12.2022 onwards on daily basis for removal of work of Aviation Globules. In this regard it is to inform you that the consent cannot be granted keeping in view that during the shut down period of above lines only 33KV Bajaura-Naggar from 132/33 KV Sub Station Bajaura will be available. Due to the winter season the load requirement of area under this Division has been increased and still will increase in coming days. The voltage in case of single circuit from 132/33KV Sub Station Bajaura remains at 29KV to 30KV and further drops down to almost 24KV-25KV on peak hours. Therefore to maintain the voltage level power cuts have to be imposed, causing hindrance of supply to the consumer of the area at their peak season. Further evacuation of power generated by the various IPPs will also disturb. This is for your kind information please.

**With Regards**

**Shift In-charge (Control Room),**

**HPSLDC, Govt. of HP,**

**Shimla (H.P.) - 171011**

**Contact No.- 0177-2838398, 0177-2837543**

**[www.hpsldc.com](http://www.hpsldc.com)**



On Mon, 28 Nov 2022 at 20:13, RTAMCJammu <[rtamcjammu@powergrid.co.in](mailto:rtamcjammu@powergrid.co.in)> wrote:

Sir

In reference to trailing email, removal work of Aviation Globules in 220KV Ad Hydro Nalagarh (Parni) line and 220KV Nalagarh Phozal line is to be carried out. For carried out this work both circuits ie. 220KV Ad Hydro Nalagarh (Parni) line and 220KV Nalagarh Phozal line are required to be taken under shutdown for safety measures from dt. 01.12.2022 onward on daily basis.

Kindly consent the shut down of above lines for removal work of Aviation Globules.

धन्यवाद और सादर /Thanks and Regards,

पाली प्रभारी/Shift Incharge,

आर.टी.ए.एम.सी./RTAMC,

ऊ.क्षे:-II,जम्मू/NR-II, JAMMU.

मोबाइल/Mobile : 09596882770, 09622138150

लैंडलाइन/Landline: (0191)2471187, 2471185

Please don't print this e-mail unless you really need to.

Save Paper Save Trees

---

**From:** "Furkan Ahmad Siddiqui {फुरकान अहमद सिद्दीकी}" <[fa.siddiqui@powergrid.in](mailto:fa.siddiqui@powergrid.in)>

**To:** "RTAMCJammu" <[rtamcjammu@powergrid.co.in](mailto:rtamcjammu@powergrid.co.in)>

**Cc:** "SK Agarwal" <[sk.agarwal@apar.com](mailto:sk.agarwal@apar.com)>, "Puneet Aggarwal" <[puneet.aggarwal@apar.com](mailto:puneet.aggarwal@apar.com)>, "Chandan Gupta" <[chandan.gupta@apar.com](mailto:chandan.gupta@apar.com)>, "Rakesh Nama"

<[rakesh.nama@apar.com](mailto:rakesh.nama@apar.com)>, "Abhishek Rai" <[abhishek.rai@apar.com](mailto:abhishek.rai@apar.com)>, "Abhay Kumar {अभय कुमार}" <[abhaykumar@powergrid.in](mailto:abhaykumar@powergrid.in)>, "Dev Kumar {देव कुमार}"

<[devkumar@powergrid.in](mailto:devkumar@powergrid.in)>, "Yogesh Dhanpal Naik {योगेश डी. नाईक}" <[yogeshdnaik@powergrid.in](mailto:yogeshdnaik@powergrid.in)>, "Sampadha . {संपदा}" <[sampadha@powergrid.in](mailto:sampadha@powergrid.in)>, [ankit@steelpro.co.in](mailto:ankit@steelpro.co.in), [somnath@steelpro.co.in](mailto:somnath@steelpro.co.in), "Parth Raval" <[parth.raval@apar.com](mailto:parth.raval@apar.com)>

**Sent:** Monday, November 28, 2022 5:38:04 PM

**Subject:** RE: Approved shutdown for ADHEPL-Nalagarh

Sir

In reference to trailing email from M/s Apar, Please confirm the availability of shutdown on both circuits at a time during the removal work of Aviation Globules .

Thanks and Regards

**Furkan Siddiqui**

**Chief Manager(ULDC)**

**RHQ-Jammu**

**POWERGRID Corporation Indial Limited**

---

**From:** Parth Raval <[parth.raval@apar.com](mailto:parth.raval@apar.com)>

**Sent:** Monday, November 28, 2022 5:18 PM

**To:** Furkan Ahmad Siddiqui {फुरकान अहमद सिद्दीकी} <[fa.siddiqui@powergrid.in](mailto:fa.siddiqui@powergrid.in)>

**Cc:** SK Agarwal <[sk.agarwal@apar.com](mailto:sk.agarwal@apar.com)>; Puneet Aggarwal <[puneet.aggarwal@apar.com](mailto:puneet.aggarwal@apar.com)>; Chandan Gupta <[chandan.gupta@apar.com](mailto:chandan.gupta@apar.com)>; Rakesh Nama <[rakesh.nama@apar.com](mailto:rakesh.nama@apar.com)>;

Abhishek Rai <[abhishek.rai@apar.com](mailto:abhishek.rai@apar.com)>; Abhay Kumar {अभय कुमार} <[abhaykumar@powergrid.in](mailto:abhaykumar@powergrid.in)>; Dev Kumar {देव कुमार} <[devkumar@powergrid.in](mailto:devkumar@powergrid.in)>; Yogesh Dhanpal Naik {योगेश

डी. नाईक} <[yogeshdnaik@powergrid.in](mailto:yogeshdnaik@powergrid.in)>; Sampadha . {संपदा} <[sampadha@powergrid.in](mailto:sampadha@powergrid.in)>; [ankit@steelpro.co.in](mailto:ankit@steelpro.co.in); [somnath@steelpro.co.in](mailto:somnath@steelpro.co.in)

**Subject:** RE: Approved shutdown for ADHEPL-Nalagarh

---

**Warning:** This email has not originated from POWERGRID. Do not click on attachment or links unless sender is reliable. Malware/ Viruses can be easily transmitted via email.

Dear Sir,

With reference to the trailing mail & our sub-sequent discussions, we would like to draw your kind attention on OCC remarks column of mentioned Sl. No. 1006, 1007 & 1008 wherein it has been mentioned that approved shutdown will depend upon "Subject to AD Hydro/HP consent; One ckt shutdown could be given at a time".

As you are aware of that the subjected link is 220kV D/C line, therefore we will require shutdown for both circuits during Aviation Globules removal work. Keeping view to the safety concerns as worker have to go in mid span on earth-wire for Aviation Globules removal work.

So In view of the above, we request your good self to kindly confirm the availability of shutdown on both circuits at a time during the execution of Aviation Globules removal work.

**Best Regards,**

**Parth Raval**

+91 93280 81642



**APAR Industries Limited**

301, Panorama Complex,

Vadodara

[www.apar.com](http://www.apar.com)   

---

**From:** Sampadha . {संपदा} [<mailto:sampadha@powergrid.in>]

**Sent:** 28 November 2022 10:02

**To:** Parth Raval <[parth.raval@apar.com](mailto:parth.raval@apar.com)>; Abhishek Rai <[abhishek.raai@apar.com](mailto:abhishek.raai@apar.com)>

**Cc:** Abhay Kumar {अभय कुमार} <[abhaykumar@powergrid.in](mailto:abhaykumar@powergrid.in)>; Dev Kumar {देव कुमार} <[devkumar@powergrid.in](mailto:devkumar@powergrid.in)>; Yogesh Dhanpal Naik {योगेश डी. नाईक}

<[yogeshdnaik@powergrid.in](mailto:yogeshdnaik@powergrid.in)>; Furkan Ahmad Siddiqui {फुरकान अहमद सिद्दीकी} <[fa.siddiqui@powergrid.in](mailto:fa.siddiqui@powergrid.in)>; SK Agarwal <[sk.agarwal@apar.com](mailto:sk.agarwal@apar.com)>

**Subject:** Approved shutdown for ADHEPL-Nalagarh

**CAUTION:** This email originated from outside the organization. Do not click links or open attachments unless you recognize the sender and know the content is safe.

Sir,

Please refer Sl. no. 1006,1007 & 1008 of OCC minutes wherein PTW/shutdown has been approved. It is requested to deploy the adequate team immediately in full swing to carry out the work in ADHEPL-NALAGARH TL.

Regards

Sampadha

Asst. Manager(ULDC)

RHQ, Jammu, NRTS-II

---

**From:** Furkan Ahmad Siddiqui {फुरकान अहमद सिद्दीकी}

**Sent:** Monday, November 28, 2022 9:53 AM

**To:** Sampadha . {संपदा}

**Subject:** FW: 201 OCC

---

**From:** RTAMCJammu <[rtamcjammu@powergrid.co.in](mailto:rtamcjammu@powergrid.co.in)>  
**Sent:** Saturday, November 26, 2022 5:13 PM  
**To:** Furkan Ahmad Siddiqui {फुरकान अहमद सिद्दीकी} <[fa.siddiqui@powergrid.in](mailto:fa.siddiqui@powergrid.in)>  
**Subject:** 201 OCC

Sir,

PFA

धन्यवाद और सादर /Thanks and Regards,

पाली प्रभारी/Shift Incharge,

आर०टी०ए०एम०सी०/RTAMC,

ऊ०क्षे०-II,जम्मू/NR-II, JAMMU.

मोबाइल/Mobile : 09596882770, 09622138150

लैंडलाइन/Landline: (0191)2471187, 2471185

Please don't print this e-mail unless you really need to.

Save Paper Save Trees

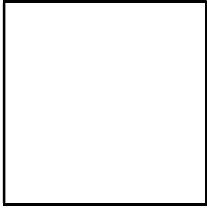

---

दावात्याग: यह ईमेल पावरग्रिड के दावात्याग नियम व शर्तों द्वारा शासित है जिसे <http://apps.powergrid.in/Disclaimer.htm> पर देखा जा सकता है।  
Disclaimer: This e-mail is governed by the Disclaimer Terms & Conditions of POWERGRID which may be viewed at <http://apps.powergrid.in/Disclaimer.htm>



---

दावात्याग: यह ईमेल पावरग्रिड के दावात्याग नियम व शर्तों द्वारा शासित है जिसे <http://apps.powergrid.in/Disclaimer.htm> पर देखा जा सकता है।  
Disclaimer: This e-mail is governed by the Disclaimer Terms & Conditions of POWERGRID which may be viewed at <http://apps.powergrid.in/Disclaimer.htm>



---

दावात्याग: यह ईमेल पावरग्रिड के दावात्याग नियम व शर्तों द्वारा शासित है जिसे <http://apps.powergrid.in/Disclaimer.htm> पर देखा जा सकता है।  
Disclaimer: This e-mail is governed by the Disclaimer Terms & Conditions of POWERGRID which may be viewed at <http://apps.powergrid.in/Disclaimer.htm>





HIMACHAL PRADESH STATE ELECTRICITY BOARD LIMITED  
(A State Govt. Undertaking)

Annexure-II

CIN: U40109HP2009SGC031255  
Address: SE (PR&ALDC), HPSEBL, Totu, Shimla-171011 (HP)  
Phone No.: 0177-2838170 (Telephone)  
Email address: srxen.scada@gmail.com  
Website address: www.hpseb.com, www.hpaldc.org

No. HPSEBL/PR&ALDC/CSCADA-15/Vol.-II/2022- *2398-2405*

Dated: - *5/11/2022*

To

**Sh. Narender Kumar Meena,**  
Chief Manager, ULDC-NR, POWERGRID,  
RHQ, NRTS-I, Faridabad.  
(E-mail: - [nkmeena@powergrid.in](mailto:nkmeena@powergrid.in)).

**Sh. Furkan Ahmad Siddiqui,**  
Chief Manager, PGCIL, NR-II,  
Rail Head Complex, Regional Head Quarters,  
Grid Bhawan, Near Bahu Plaza, Jammu-180012.  
(E-mail: - [fa.siddiqui@powergrid.in](mailto:fa.siddiqui@powergrid.in)).

**Subject: - Shutdown to execute the OPGW laying work on Nogli-Kumarsain 66 kV Transmission Line.**  
Reference: - i) Sr. Executive Engineer, ES Division, HPSEBL, Kotla email dated 31.10.2022 and office letter No. HPSEBL/ESDK/DB 20/2022-23- 3021-24 dated 04.11.2022 (Copy enclosed).  
ii) M/s Ten Dot Net Cable Pvt. Ltd. letter No. TDNCPL/22-23/Letter/OPGW/0186 dated 03.11.2022.

Sirs,

With reference to the subject cited above and telephonically discussion of HPSEBL authority today on dated 04.11.2022 regarding shutdown to execute the OPGW installation work on 66 kV Nogli-Kumarsain transmission line with your goodself, it is submitted that HPSEBL intends to complete the work of laying of OPGW on the subject cited transmission line, however, due to lean hydro generation and therefore load availability constraints, HPSEBL is not in position to provide the shutdown on daily basis as desired by M/s Ten Dot Net Cable Pvt. Ltd. for laying of OPGW during winter season. It is further informed that to complete the remaining OPGW laying work on 66 kV Nogli- Kumarsain transmission line may deferred till May, 2023.

Meanwhile, the OPGW laying work can be started on 220 kV Bhaba-Kashang transmission line on non-auto mode basis. It is also intimated that about 12 KM OPGW has already been laid on 220 kV Bhaba-Kashang transmission line and aviation globules remains uninstalled from this line since long. Therefore, M/s Ten Dot Net Cable Pvt. Ltd. may be asked to start the OPGW laying work on 220 kV Bhaba-Kashang transmission line.

**DA: - As above.**

Yours sincerely,

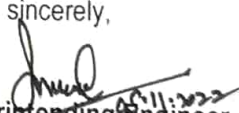
  
**Superintending Engineer,**  
PR&ALDC, HPSEB Ltd.,  
Totu, Shimla-11.  
E-mail: - [sepraldchpesbl@gmail.com](mailto:sepraldchpesbl@gmail.com)

**Copy of the above is forwarded to the following for information please:-**

1. The Chief Engineer (Sys. Op.), HPSEBL, Vidyut Bhawan, Shimla-4.
2. The Chief Engineer (ES), Electrical System Complex, HPSEBL, Mattansidh, Hamirpur-177001.
3. The Superintending Engineer, ES Circle, HPSEBL, Totu, Shimla-11.
4. The Sr. Executive Engineer, ES Division, HPSEBL, Kotla (Jeori) w.r.t email & letter referred above.
5. The Sr. Executive Engineer, PLCC Division, HPSEBL, BBMB Colony, Sundernagar.
6. Sh. Debasish Das, Project Manager, Ten Dot Net Cable Pvt, Ltd., 95/15, Bose Pukur Road, Kolkata-700042. (Email: - [d.dastdncpl@gmail.com](mailto:d.dastdncpl@gmail.com))

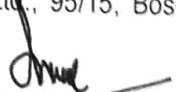
  
**Superintending Engineer,**  
PR&ALDC, HPSEB Ltd.,  
Totu, Shimla-11.

**Request to extent the Shutdown timings on daily basis from 09:00 Hrs. to 18:00 Hrs. for OPGW installation work at Nogli-Kumarsain 66 KV TL.**

5 messages

**DEBASISH DAS** <d.dastdncpl@gmail.com>

Mon, Oct 31, 2022 at 12:59 PM

To: "Yogesh Dhanpal Naik {योगेश डी. नाईक}" &lt;yogeshdnaik@powergrid.in&gt;

Cc: Kulvinder Singh {कुलविन्दर सिंह} &lt;kulwinder@powergrid.in&gt;, Sr EE SCADA HPSEBL &lt;srxen.scada@gmail.com&gt;, Amit Kumar Singh {अमित कुमार सिंह} &lt;amitsinghnikumbh@powergrid.in&gt;, Furkan Ahmad Siddiqui {फुरकान अहमद सिद्दीकी} &lt;fa.siddiqui@powergrid.in&gt;, "Sampadha . {Sampadha}" &lt;sampadha@powergrid.in&gt;, arunmaity\_in &lt;arunmaity\_in@yahoo.com&gt;, manotosh mandal &lt;mandalmanotosh96@gmail.com&gt;

Dear Sir,

With reference to the above subject matter, OPGW installation work has been hampered on daily basis on Nogli-Kumarsain 66 KV rail Pole Structures line due to Shutdown approved daily after 12 A.M .

On today, the shut down was received at 12:50 Hrs. for the said link where the OPGW installation team arrives at the site every day at 9 a.m.

Due to the above reasons, OPGW installation work has been interrupted and insufficient progress has been made after the day's work due to the shortest time shutdown provided by HPSEBL.

Under the above circumstances, you are once again requested to kindly extend the Shutdown timings on daily basis from 09:00 Hrs. to 18:00 Hrs. so that the balance OPGW Installation work for the said link can be carried out at the earliest.

Further, in no case, we should not be penalized from any kind of recovery for delay completion of the entire project work.

--

Thanks &amp; Regards

**DEBASISH DAS**

for Ten Dot Net Cable Pvt. Ltd.

Corporate Office : 95/15 Bose Pukur Road, Kolkata-700042

Mob:8334004408

**Sr EE SCADA HPSEBL** <srxen.scada@gmail.com>

Mon, Oct 31, 2022 at 3:51 PM

To: hpsebl kotla &lt;srxenescotla@gmail.com&gt;

With regards,

Sr. Executive Engineer (Communication),  
O/o Superintending Engineer (PR&ALDC),  
HPSEB Ltd., Totu, Shimla-11

[Quoted text hidden]

Electrical System Division Kotla <srxeneskotla@gmail.com>

To: CE ES <chiefengineeres@gmail.com>, Se Sldc <sehpsldc@gmail.com>, Sr EE SCADA HPSEBL <srxen.scada@gmail.com>, aeesnogli@gmail.com, seesshimla <seesshimla@gmail.com>

Mon, Oct 31, 2022 at 11:50 AM

availability of manpower

Dear Sir,

With reference to your mail, it is to inform you that this office intends to complete the installation work of OPGW on 66KV Nogli-Kumarsain Line. But it should be kept in mind that this office cannot afford load shedding and generation loss on account of shutdown for your work. It is pertinent to mention here that this office had earlier informed your good self through various correspondences regarding the difficulties which will be faced due to non-availability of load from Gumma S/Stn. after peak generation season, but you didn't increase the manpower for work.

Also shutdown was approved from 15/09/2022 but your team started the work on 30/09/2022 onwards and due to which a total of around 15days of shutdown period wasn't utilised, as at that time load was available from Gumma S/Stn.

Now, keeping in view the current scenario this office proposes following:

1. Load is not, and will not be available from Gumma S/Stn, therefore shutdown timing can't be increased as it is proportional to load availability. Therefore, complete the work till the approval of shutdown period against the shutdown timing allowed daily.
2. If above proposal is not acceptable to you, then the shutdown can be cancelled and remaining work shall be planned after availability of load from Gumma S/Stn. which is not possible before 05/2023.

Therefore, in view of above it is requested to convey the decision to this office at the earliest please.

**NOTE: On 31/10/2022 i.e. today your team did not returned the shutdown when demanded by this office at 16:00Hrs, due to which load shedding and power cuts were affected in various sub-stations till 17:35Hrs.**

**If same is repeated again, this office will be left with no option other than cancellation of shutdown from next day onwards.**

This is for your kind information please.

--

Sir

Enclosed herewith above cited document please.

With regards

Sr. Executive Engineer  
ES Division  
HPSEBL Kotla (Jeori)

Electrical System Division Kotla <srxeneskotla@gmail.com>

Mon, Oct 31, 2022 at 6:04 PM

To: CE ES <chiefengineeres@gmail.com>, DEBASISH DAS <d.dastdncpl@gmail.com>, Se Sldc <sehpsldc@gmail.com>, Sr EE SCADA HPSEBL <srxen.scada@gmail.com>, aeesnogli@gmail.com, seesshimla <seesshimla@gmail.com>

[Quoted text hidden]

Electrical System Division Kotla <srxeneskotla@gmail.com>

Mon, Oct 31, 2022 at 6:10 PM

To: CE ES <chiefengineeres@gmail.com>, DEBASISH DAS <d.dastdncpl@gmail.com>, Se Sldc <sehpsldc@gmail.com>, Sr EE SCADA HPSEBL <srxen.scada@gmail.com>, "Yogesh Dhanpal Naik (योगेश डी. नाईक)" <yogeshdhaik@powergrid.in>, aeesnogli@gmail.com, seesshimla <seesshimla@gmail.com>

Dear Sir,

With reference to your mail, it is to inform you that this office intends to complete the installation work of OPGW on 66KV Nogli-Kumarsain Line. But it should be kept in mind that this office cannot afford load shedding and generation loss on account of shutdown for your work. It is pertinent to mention here that this office had earlier informed your good self through various correspondences regarding the difficulties which will be faced due to non-

Request to extend the Shutdown timings on daily basis from 09:00 Hrs. to 18:00 Hrs. for OPGW installation work at N...  
availability of load from Gumma S/Stn. after peak generation season, but you didn't increase manpower for work.

Also shutdown was approved from 15/09/2022 but your team started the work on 30/09/2022 onwards and due to which a total of around 15days of shutdown period wasn't utilised, as at that time load was available from Gumma S/Stn.

Now, keeping in view the current scenario this office proposes following:

1. Load is not, and will not be available from Gumma S/Stn, therefore shutdown timing can't be increased as it is proportional to load availability. Therefore, complete the work till the approval of shutdown period against the shutdown timing allowed daily.
2. If above proposal is not acceptable to you, then the shutdown can be cancelled and remaining work shall be planned after availability of load from Gumma S/Stn. which is not possible before 05/2023.

Therefore, in view of above it is requested to convey the decision to this office at the earliest please.

**NOTE: On 31/10/2022 i.e. today your team did not returned the shutdown when demanded by this office at 16:00Hrs, due to which load shedding and power cuts were affected in various sub-stations till 17:35Hrs.**

**If same is repeated again, this office will be left with no option other than cancellation of shutdown from next day onwards.**

This is for your kind information please.

With regards

**Sr. Executive Engineer  
ES Division  
HPSEBL Kotla (Jeori)**

[Quoted text hidden]



# HIMACHAL PARDESH STATE ELECTRICITY BOARD LIMITED

"A State Govt. Undertaking"

Registered Office  
Number(CIN)  
GST NO HPSEBL  
Phone No  
Website Address  
Email Address

Vidyut Bhawan, HPSEBL, Shimla-171004 (H.P.)  
U40109HP2009SGC 31255  
02 AACCH4894EHZB  
0177-2803600 (Office) 2813563.  
www.hpseb.com  
srxeneskotla@gmail.com

No. HPSEBL/ESDK/DB-20/2022-23-

To

3021-24

Dated: 04/11/2022

M/s TAN DOT Net Cable Pvt Ltd  
Corporate Office 95/15 Bose Pukur Road,  
Kolkata-700042.

Subject: - Regarding request to considering the Idling charges @ 40,000/- per day due to non-providing the Shutdown to execute the OPGW Installation work for Nogli-Kumarsain 66KV T/Line.

Reference: Your Office Letter No - 0186 dated 03/11/2022

Sir,

With respect to the letter under reference vide which your office had claimed for Idling Charges @ 40,000/- per day due to non-providing the shutdown to execute the OPGW installation work for Nogli-Kumarsain 66KV T/Line from this office. In this regard it is hereby submitted that this office clearly rejects the claim of Idling Charges on account of the contents of this letter which are self-explanatory. It is intimated that shutdown on 66KV Nogli-Kumarsain T/Line was approved from 15/09/2022 to 15/11/2022, but it is **regretted** to again state that your firm started the work from 30/09/2022 onwards due to which almost 15 days of shutdown period was wasted. It is pertinent to mention here that during that period load was available from alternate source i.e. 66/22KV Gumma S/Stn. and the quantum of work which is pending currently would have been easily completed, if the shutdown period was utilized by your firm. Also, this office had written a letter for increase in manpower dated 11/10/2022 wherein it was also mentioned that LHEP Dam Site of SJVNL, Water Lifting Schemes & local public is facing problems due to low voltage being received from 66/22KV Gumma S/Stn during the period of shutdown and request was made to increase the manpower but your firm didn't paid any heed to it.

It is also intimated that this office intends to complete the work awarded to your firm but it should be kept in mind that the sole purpose of this office is to provide un-interrupted and reliable power supply to consumers and this office cannot afford load shedding & generation loss which was occurred on 31/10/2022 due to non-return of shutdown by your site team (Cost of which will be shared separately) and onus of any financial loss occurred to HPSEBL that day will lie upon you.

Further, this office is unable to provide the shutdown desired by your firm due to load availability constraints which also are not in the hands of this office. Therefore, in view of above this office propose either to complete the work in the shutdown timings provided by this office, which will be around 03Hours daily or demobilize the team in accordance with LOA. This is for kind information and taking further necessary action at your end please.

**This office is not responsible for any idling charges claimed.**

DA: NA



Thank You.

  
Sr. Executive Engineer,  
Electrical System Division,  
HPSEB Ltd. Kotla (Jeori).



**HARYANA VIDYUT PRASARAN NIGAM LIMITED**

Regd. Office: Shakti Bhawan, Plot No. C-4, Sector-6, Panchkula, 134109.

Corporate Identity Number: - U4010HR1997SGC033683

Website: - www.hvvn.org.in, Email ID: - companysecy@hvvn.org.in

O/o XEN SCADA EMS, HVPNL, Panipat.

Phone No. 0180- 2671788

Correspondence Email ID: [xenscada@hvvn.org.in](mailto:xenscada@hvvn.org.in)

To

The Chief Manager (NR-ULDC),  
PowerGrid, Delhi.

Memo no. Ch.165 SCADA- 100

Dated: 28.10.2022

**Subject: - Regarding Availability for the 4th quarter of FY 2021-2022 of ULDC Phase-2 SCADA system.**

Please refer to this office earlier correspondences vide memo no. Ch-89/SCADA -100 dated 01.08.2022 & Ch- 93 / SCADA-100 dated 04.08.2022 vide which availability of the said quarter have been intimated to M/s Siemens.

Recently, a meeting was held with Project Manager of M/s Siemens in the chamber of undersigned wherein M/s Siemens has requested to review the calculation of availability of the quarter. As per their claim, non-availability hours of the said quarter shall be halved due to availability of at least one engineer at site. It is also stated by M/s Siemens that PowerGrid agree with the same.

However as per contract of the clause each engineer has their designated role and it is clearly mentioned in the contract and reiterated as below: -

*As per AMC contract agreement clause 4.2.1. "The contractor's on-site support for Main Control Centre shall be standard hours of service i.e., Monday to Saturday- 9:00am to 5:30pm local time (IST), excluding Public and Owner company holidays, throughout a year, **at least one Software Engineer and One Hardware Engineer having expertise in SCADA/EMS system shall be available during the standard hours of service at each Main Control Centre.**"*

*Further as per clause 4.5.1, details of system under different severity levels, Severity-2 outages/disruptions defines, "**non-availability of designated contractor's man-Power at Control Centre as well as required inventory of spares specified here.**"*

It is pertinent to mention that M/s Siemens couldn't provide the engineer for 2 months in the said quarter. However, being a contractual owner of the project, it is requested to please clarify whether the calculation made by HVPNL for the said quarter is as per contract or not. In case not, suitable justification may also be submitted for further processing.

Matter urgent please.

DA/As above.

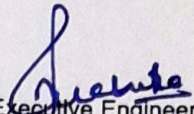
  
Executive Engineer,  
SCADA / EMS Mtc. Division,  
HVPNL, Sewah (Panipat)

CC to:

1. CE/ P&M, HVPNL, Panchkula.
2. Sh. Y. K. Dixit, Executive Director, PowerGrid, Delhi.
3. SE/SLDC 'D&C', HVPNL, Panchkula.
4. Sh. Namit Kumar, Head Life Cycle Management-Grid Control Business-Siemens, Gurugram.
5. Sh. Sumit Bhatnagar, Project Manager, ULDC Phase-2, M/s Siemens, Gurugram.



## **HARYANA VIDYUT PRASARAN NIGAM LIMITED**

Regd. Office: Shakti Bhawan, Plot No. C-4, Sector-6, Panchkula, 134109.

Corporate Identity Number: - U4010HR1997SGC033683

Website: - [www.hvpng.org.in](http://www.hvpng.org.in), Email ID: - [companysecy@hvpng.org.in](mailto:companysecy@hvpng.org.in)

O/o XEN SCADA EMS, HVPNL, Panipat.

Phone No. 0180- 2671788

Correspondence Email ID: [xenscada@hvpng.org.in](mailto:xenscada@hvpng.org.in)

To

Project Manager, ULDC Phase-2 (email: - [sumit.bhatnagar@siemens.com](mailto:sumit.bhatnagar@siemens.com))  
M/s Siemens Pvt. Ltd.  
Gurugram.

Memo no. Ch. 89/ SCADA-100

Dated:01.08.2022

**Subject: - Availability for the 4th quarter of FY 2021-2022 of ULDC Phase-2 SCADA system.**

Please refer to the AMC report shared by M/s Siemens site engineer for the 4<sup>th</sup> quarter of FY 2021-2022 i.e., Jan-2022 to March-2022.

In this regard it is to inform you that on account of non-availability of one designated site engineer for the Month of Feb-March 2022, the quarterly availability is coming out to 85.22% (complete calculation sheet is attached herewith). So please submit the quarterly bills accordingly. Further if there are any objections on calculated availability, the same may be submitted by 3<sup>rd</sup> August,2022. This is for your information and necessary action please.

Matter Urgent Please.

DA/As above.

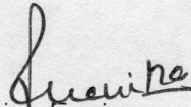
  
Executive Engineer,  
SCADA / EMS Mtc. Division,  
HVPNL, Sewah (Panipat)

CC to:

1. CE/ P&M, HVPNL, Panchkula.
2. SE/SLDC D&C, HVPNL, Panchkula.
3. Sh. Narendra Kr. Meena, Chief Manager (NR-ULDC), PowerGrid.
4. Sh. Namit Kumar, Head Life Cycle Management-Grid Control Business—  
Siemens, Gurugram.



**SIEMENS**



पावरग्रिड



SCADA / EMS Systems for NRLDC and SLDCs of Northern Region  
 Contract No. CC-CS/275-NR1/SCADA-1602/3/G5/NOA-1/4439-4444

**1.23 Defect Reporting & downtime calculation**

Description of the problem reported	Severity level	From time	To time	Total down time
Non availability of designated site eg.	2	1-02-2022	31-03-2022	399 Hr.

$$\text{System Availability of the month} = \frac{\text{THQ} - (S1 \times 1 + S2 \times 0.8 + S3 \times 0.5)}{\text{THQ}} \times 100\% = \frac{2160 - (399 \times 0.8)}{2160}$$

System availability: ...85.22...% = 85.22

THQ is total hours in the quarter.  
 S1 is the total non-available hours in Severity Level-1 in the quarter.  
 S2 is the total non-available hours in Severity Level-2 in the quarter.  
 S3 is the total non-available hours in Severity Level -3 in the quarter.

Severity 1 (Urgent) – Complete System failure, Loss or Failure of any major Subsystem.  
 Severity 2 (Serious) - Degradation of services or critical function.  
 Severity 3 (Minor) - Any other system defect which does not impact on system operation.

This is to certify that the maintenance work for SCADA/EMS system has been carried out satisfactorily

Remarks: *Jan-March-2022, format for AMC may be verified with AE-IT & AE-Hardware for their relevant portion & their remark may be taken here.*

Date: *11/04/22*  
 Signatures: *[Signature]* Assistant Engineer  
 EMS/SCADA Divn.  
 HVPNL, SEWAH, PNP.  
 Customer

SIEMENS

कार्यन्वयन हेतु अनुमोदित/ जारी।  
 Approved & Released for Implementation

In Project: *[Signature]*

Ref. Sign. (NOA Ref.): *[Signature]*

Document Name: Maintenance Report  
 Proprietary Information of Siemens.



Revision: R0  
 Page 26 of 26

*[Signature]* 29/7/22  
 Assistant Engineer CIT  
 EMS/SCADA Divn.  
 HVPNL, SEWAH, PNP.

*bilal in Reports found ok*  
*[Signature]* Assistant Engineer  
 EMS/SCADA Divn.  
 SEWAH, PNP.

DATE	TIME HOUR	HOURS	TOTAL CUMALATIVE HOURS OF NON AVAILABILITY
01-02-2022	9.00	17.30	8.30
02-02-2022	9.00	17.30	8.30
03-02-2022	9.00	17.30	8.30
04-02-2022	9.00	17.30	8.30
05-02-2022	9.00	17.30	8.30
06-02-2022	Sunday		
07-02-2022	9.00	17.30	8.30
08-02-2022	9.00	17.30	8.30
09-02-2022	9.00	17.30	8.30
10-02-2022	9.00	17.30	8.30
11-02-2022	9.00	17.30	8.30
12-02-2022	9.00	17.30	8.30
13-02-2022	Sunday		
14-02-2022	9.00	17.30	8.30
15-02-2022	9.00	17.30	8.30
16-02-2022	Holiday		
17-02-2022	9.00	17.30	8.30
18-02-2022	9.00	17.30	8.30
19-02-2022	9.00	17.30	8.30
20-02-2022	Sunday		
21-02-2022	9.00	17.30	8.30
22-02-2022	9.00	17.30	8.30
23-02-2022	9.00	17.30	8.30
24-02-2022	9.00	17.30	8.30
25-02-2022	9.00	17.30	8.30
26-02-2022	9.00	17.30	8.30
27-02-2022	Sunday		
28-02-2022	9.00	17.30	8.30
01-03-2022	Holiday		
02-03-2022	9.00	17.30	8.30
03-03-2022	9.00	17.30	8.30
04-03-2022	9.00	17.30	8.30
05-03-2022	9.00	17.30	8.30
06-03-2022	Sunday		
07-03-2022	9.00	17.30	8.30
08-03-2022	9.00	17.30	8.30
09-03-2022	9.00	17.30	8.30
10-03-2022	9.00	17.30	8.30
11-03-2022	9.00	17.30	8.30
12-03-2022	9.00	17.30	8.30
13-03-2022	Sunday		
14-03-2022	9.00	17.30	8.30
15-03-2022	9.00	17.30	8.30
16-03-2022	9.00	17.30	8.30
17-03-2022	9.00	17.30	8.30
18-03-2022	Holiday		
19-03-2022	9.00	17.30	8.30
20-03-2022	Sunday		
21-03-2022	9.00	17.30	8.30
22-03-2022	9.00	17.30	8.30
23-03-2022	Holiday		
24-03-2022	9.00	17.30	8.30
25-03-2022	9.00	17.30	8.30
26-03-2022	9.00	17.30	8.30
27-03-2022	Sunday		
28-03-2022	9.00	17.30	8.30
29-03-2022	9.00	17.30	8.30
30-03-2022	9.00	17.30	8.30
31-03-2022	9.00	17.30	8.30

Total HOURS IN THE QUARTER	2160.00
TOTAL NON AVAILABILITY HOURS	399
SEVERITY	2
SYSTEM AVAILABILITY	85.22222222

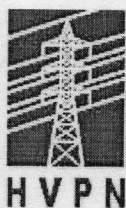

## **HARYANA VIDYUT PRASARAN NIGAM LIMITED**

Regd. Office: Shakti Bhawan, Plot No. C-4, Sector-6, Panchkula, 134109.

Corporate Identity Number: - U4010HR1997SGC033683

Website: - www.hvpn.org.in, Email ID: - companysecy@hvpn.org.in

O/o XEN SCADA EMS, HVPNL, Panipat.

Phone No. 0180- 2671788

Correspondence Email ID: [xenscada@hvpn.org.in](mailto:xenscada@hvpn.org.in)

To

Project Manager, ULDC Phase-2 (email: - sumit.bhatnagar@siemens.com)  
M/s Siemens Pvt. Ltd.  
Gurugram.

Memo no. Ch-93/ SCADA- 100

Dated:04.08.2022

**Subject: - Availability for the 4th quarter of FY 2021-2022 of ULDC Phase-2 SCADA system.**

Please refer to this office letter vide memo no. Ch-89/SCADA-100 dated 01.08.2022 & your office correspondences addressed to Sh. Narendra Kr. Meena, Chief Manager (NR-ULDC), PowerGrid regarding the subject cited above.

In this regard it is to inform you that availability of the said quarter has been calculated following the contractual agreement of AMC signed between HVPNL & M/s Siemens and both are legally bind to follow the agreement.

As per AMC contract agreement clause 4.2.1. "The contractor's on-site support for Main Control Centre shall be standard hours of service i.e., Monday to Saturday- 9:00am to 5:30pm local time (IST), excluding Public and Owner company holidays, throughout a year, at least one Software Engineer and One Hardware Engineer having expertise in SCADA/EMS system shall be available during the standard hours of service at each Main Control Centre."

Further as per clause 4.5.1, details of system under different severity levels, Severity-2 outages/disruptions, "non-availability of designated contractor's man-Power at Control Centre as well as required inventory of spares specified here."

Apart from this, this office has asked for joint discussion on several occasions, however no reply has been received till now. It is once again requested to have a joint meeting along with PowerGrid with your agenda points.

Executive Engineer,  
SCADA / EMS Mtc. Division,  
HVPNL, Sewah (Panipat)

CC to:

1. CE/ P&M, HVPNL, Panchkula.
2. SE/SLDC D&C, HVPNL, Panchkula.
3. Sh. Narendra Kr. Meena, Chief Manager (NR-ULDC), PowerGrid.
4. Sh. Namit Kumar, Head Life Cycle Management-Grid Control Business-Siemens, Gurugram.

**Installation of new Interface Energy meters, AMR system under the scheme “5 min Interface Energy Meter along with AMR system-Northern Region”**

S. No.	Items	Details
1.	Name of Scheme	Supply and installation of 5 min Interface Energy Meter along with AMR system- Northern Region
2.	Scope of the scheme	<ol style="list-style-type: none"> <li>1. Supply and installation of 5 min Interface Energy Meters for all ISTS metering points of Northern region.</li> <li>2. Supply and installation of AMR system along with DCU, Ethernet Switch and other accessories at substation end and AMR software along with servers, database, printer, firewall etc. at RLDC/RPC end to receive 5 min load profile data in auto mode.</li> <li>3. Provision of streaming online instantaneous MW data at a user configurable rate (minimum 1 min) at SLDCs via AMR system.</li> <li>4. AMC for complete AMR system for 10 years</li> </ol> <p>The complete scope of AMR scheme shall be as per the Technical Specification (TS) circulated by NPC Division, CEA vide letter dtd. 6<sup>th</sup> July 2022.</p>
3.	Conceptual Architecture of AMR connectivity of ISTS Meters	<b>Annexure</b>
4.	Objective / Justification	<p>For Indian Power system, commercial settlements of energy generation and consumption are being computed through Availability Based Tariff (ABT) and Deviation Settlement Mechanism (DSM) which are in vogue for energy accounting. Availability Based Tariff was implemented in India in 2002/2003 considering the settlement period as 15-min.</p> <p>Government of India (GoI) has set a Renewable Energy (RE) target of 500GW by 2030. The need for implementing a 5-minute scheduling, accounting and settlement at the Inter State level has been recommended by FOR Sub-Group report, 2018 considering the variability of load due to large RE penetration in the coming years. A PAN India pilot project on 5-minute metering was implemented as per the directive from Hon’ble CERC. A report on the pilot project covering implementation aspects, challenges and suggested way forward has been submitted by POSOCO for perusal of the Hon’ble Commission and further directions. This issue was discussed in OCC/TCC/RPC meetings at regional level and it was discussed to replace the entire fleet of existing SEMs (15-min Block) with Interface Energy Meters (5-min Block) and implementation of Automated Meter Reading (AMR) and Meter Data Processing (MDP) system for efficient and faster accounting.</p>

		Moreover, in view of the new DSM regulation and its amendments, which are more stringent, there is a need expressed by States to get streaming online instantaneous MW data at a user configurable rate (minimum 1 min) at SLDCs via AMR system. This instantaneous MW data is only for the purpose of taking actions/decisions in real time for grid monitoring & discipline.
5.	Estimated Cost	Rs. 150 Crore (approx.)
6.	Implementation timeframe	Approx. 30 months from gazette Notification.
7.	Implementation Mode	Through POWERGRID-RTM

Substation

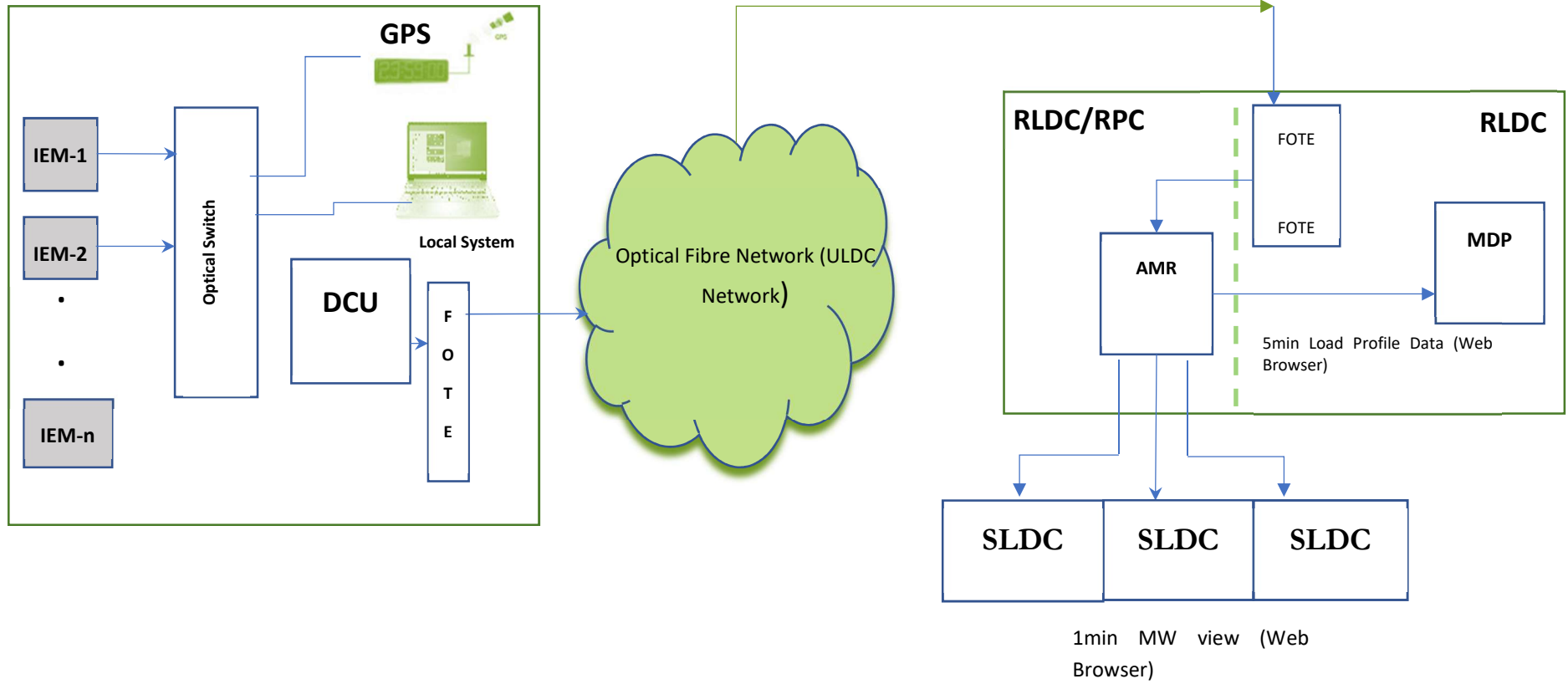

**Minutes** of meeting on microwave tower at Bawana held in the office of DGM  
(SLDC) / DTL, Minto Road, New Delhi on 01/10/2021

Following executives attended the meeting:

Delhi Transco Limited:

1. Shri Sarada Prasanna Routray – Manager (Communication)
2. Shri S. K. Tyagi – Assistant Manager (Communication)

HVPNL:

1. Shri Rajesh Sharma – Asst. Executive Engg.

M/s Maa Chintpurni Patiala

1. Sh. Yogesh Goel (Authorized representative)

Following points were deliberated in the meeting:

1. The Microwave tower standing tall at Bawana belongs to HVPNL. HVPNL has sold the above said tower to M/s Maa Chintpurni, Patiala at scrap value of Rs. 11,88,859/- (including taxes) in e-auction dated 24.07.2020 for tower weight of 66.8MT.
2. DTL requested HVPNL to spare the microwave tower in the present condition (no dismantling) as it is being used by DTL.
3. An arrangement has been drawn out to settle the matter mutually as per deliberation in the 18<sup>th</sup> meeting of TeSt Sub-Committee (copy enclosed at cp side), where upon NRPC directed both the utilities to resolve the matter bilaterally as per point 3.2.6. The proposed arrangement is to swap DTL's similar quantity scrap as per lifting order.
4. DTL will arrange similar qty of scrap as per lifting order for said purpose from its sites.
5. MW antennas, RF Cables etc on Tower belongs to HVPNL will be dismantled and handed over to SLDC Panipat office of HVPNL by M/s Maa Chintpurni, Patiala.
6. M/s Maa Chintpurni Patiala is in agreement to the above discussed solution/arrangement to settle the matter.
7. HVPNL will put the case to its management for final decision with respect to this arrangement, as proposed by DTL & agreed by auctioner i.e., Maa Chintpurni Patiala.
8. If HVPNL Management agrees to this arrangement, then the said asset of MW Tower (Bawana) will transferred to DTL for all the intents & purposes.

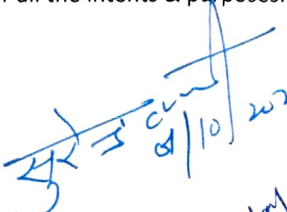
  
Yogesh Goel  
1-10-2021

M/s Maa Chintpurni Patiala

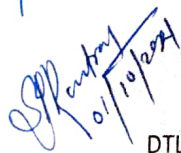
  
DTL

  
HVPNL



## HARYANA VIDYUT PRASARAN NIGAM LIMITED

Regd. Office, Shakti Bhawan, Plot No. C-4, Sector-6, Panchkula, 134109  
 Corporate Identity Number U40101HR1997SGC033683  
 Website: www.hvprn.org.in Email ID: xensldertumtc@hvprn.org.in,  
 Phone No. 0180-2664852

To

The Manager (Technical) Communication,  
 SLDC, Minto Road, New Delhi  
 Email: [connectdtl@gmail.com](mailto:connectdtl@gmail.com)

Kind Attention  
 Sh. S.P. Rautaray

Memo No. - Ch- 3 TGC 30/01/21

Dated - 10.12.2021

Subject: Dismantlement of Microwave Radio Tower asset of HVPNL from 400KV DTL, Bawana.

It is to inform that the request of DTL regarding utilization of asset of HVPNL of MW Tower installed at 400KV DTL, Bawana has been considered by HVPNL management on following terms & conditions as under:

1. In principal approval for providing equal iron scrap of weight 66.8 MT (MW tower weight of Bawana site) by DTL to M/s Maa Chintapurni Traders Patiala from DTL site / stores.
2. Transferring of assets of MW Tower installed at 400KV S/Stn, Bawana to DTL for all intents & purposes

Therefore it is requested to take up the matter accordingly to provide the scrap equal to weight of MW Tower (66.8 MT) to M/s Maa Chintapurni Traders Patiala in presence of HVPNL representative & take over the asset of MW Tower of 400KV S/Stn Bawana.

  
 Executive Engineer,  
 SLDC Const. -cum- Mtc. Division,  
 HVPNL, Sewah (Panipat)

CC to -

1. The CE/SO & Comml, HVPNL, Panchkula.
2. The SE / SLDC D&C Circle, HVPNL, Sewah (Panipat).
3. Chief Manager / PGCIL, Katwaria Sarai, New Delhi for information & necessary action.